

Summary

The usefulness and validity of the Eastman thermocell equation are demonstrated by calculations based upon thermocell e. m. f. measurements and conductance measurements which are reported for the first time. Entropies of transfer for Li^+ , Na^+ , K^+ , NH_4^+ , Br^- , OH^- and a series of the first five symmetrical tetraalkylammonium ions are presented. The absolute partial

molal entropy of hydrogen ion is calculated from the data and given as -2.1 ± 0.4 e. u., based upon the absolute partial molal entropy of Br^- determined by the Eastman equation with the assumption of zero entropy of transfer for large tetraalkylammonium ions. The tabulated ionic entropies of transfer are shown to be valid on a relative basis regardless of this assumption.

SAN FRANCISCO 22, CALIF.

RECEIVED MAY 16, 1949

[CONTRIBUTION FROM THE LABORATORIES OF THE ROCKEFELLER INSTITUTE FOR MEDICAL RESEARCH]

A Study of the Diffusion of Potassium Chloride in Water at 25° with the Gouy Interference Method

BY LOUIS J. GOSTING¹

Introduction.—The object of this research was the determination, with the aid of the Gouy interference method, of the diffusion coefficients of potassium chloride for comparison with the results of Harned and Nuttall who used a conductance method. With the diffusion cells now available this optical procedure cannot be used with sufficiently dilute solutions to obtain a direct comparison with the Onsager-Fuoss theory. Fortunately, however, Harned and Nuttall have extended their initial measurements at low concentrations,² which are in excellent agreement with the theory, up to $0.5 N$,³ thereby making possible a direct comparison of the two experimental procedures. In this manner it is hoped to establish the validity of a precise optical procedure that, in contrast with the conductance method, is also applicable to the study of the diffusion of proteins and related substances.

In addition to the comparison with the conductometric results the measurements have been extended to concentrated solutions and the wavelength term in the theory of the Gouy method confirmed experimentally. Some improvements in experimental procedure are also reported.

Experimental.—The apparatus used in the present research is a modification of the electrophoresis equipment developed in this laboratory⁴ in which the optical "lever arm," b , is 191.043 cm. The modifications are based on the experience gained in the construction of the diffusion equipment at the University of Wisconsin^{5,6} and are as follows:

(1) In order to avoid excessive heating of the illuminated slit in the object plane of the schlieren lens and the resulting vertical movement of this slit as its ambient temperature rises during an experiment the H4 mercury vapor lamp was mounted separately and the arc focussed on the slit with the aid of a pair of condensing lenses of 40 mm. diameter and 85 mm. focal length. Heating of the slit was further reduced and possible distortion of the Gouy

fringes from imperfections in the Wratten 77A filter was avoided by placing this filter between the condensing lens and the slit.

(2) As in the earlier work⁶ a Tiselius cell, with the height of the top section increased to extend out of the thermostat liquid, was used as the diffusion cell, the technique of Kahn and Polson⁷ being employed to sharpen the boundary after its displacement to the center of the channel. The support for this cell was provided with a masking arrangement that will be described below in connection with the photographic procedure. It was suspended in the water-bath with the aid of a steel frame bolted directly to the concrete block supporting this bath. Moreover, the optical bench was anchored to this block so that the position of the diffusion cell was fixed with respect to the other elements of the optical system.

(3) In order to minimize the movement of one optical element with respect to another the vertical steel plates carrying, respectively, the schlieren lens and bath window, the second thermostat window assembly, and the plate holder were braced with angle iron to the optical bench.

(4) The schlieren camera described in a previous communication⁴ was replaced by the plate holder shown in perspective in Fig. 1. In this figure the hinged back, B, of the plate holder, P, is swung open and the dark slide, S, partially removed in order to show the gate, G, in the fixed plate, A, through which light reaches the emulsion. As is indicated at C the upper edge of A is bevelled and the plate P provided with a matching bevel so that gravity insures light-tight contact between the two plates as P is moved to each of the eight positions at which photographs can be made on a 6×9 cm. plate without overlapping of the images. Although not shown in the figure the rectangular box, E, that carries the plate A is carried, in turn, by a vertical plate from the optical bench. A flap shutter in this box is operated by the knob, K, while that, D, with the removable stop-pin, F, connects with a shaft in the box to which are attached, at 90° intervals, four masking vanes. Any one of these vanes may thus be swung into place in front of the gate G in bracketing, as will now be described, the diffusion channel fringes with those from a reference opening.

Photographic Procedure.—For the computation of the diffusion coefficient, D , by the Gouy procedure the number, j_m , of fringes in the pattern must be known in addition to the movement of these fringes as the boundary spreads. If a is the dimension of the diffusion channel parallel to the optic axis and Δn the difference of refractive index between solution and solvent, $j_m = a \Delta n / \lambda$, where λ is the wave length of the light. In general j_m is a compound number and a count of the fringes in the Gouy pattern gives only the integral part, I . If D is to be obtained from patterns having as few as fifty fringes and is to be

(1) National Research Council Fellow in Chemistry.

(2) Harned and Nuttall, *THIS JOURNAL*, **69**, 736 (1947).

(3) Harned and Nuttall, *ibid.*, **71**, 1460 (1949).

(4) Longworth, *Ind. Eng. Chem., Anal. Ed.*, **18**, 219 (1946).

(5) Gosting, Hanson, Kegeles and Morris, *Rev. Sci. Instr.*, **20**, 209 (1949).

(6) Gosting and Morris, *THIS JOURNAL*, **71**, 1998 (1949).

(7) Kahn and Polson, *J. Phys. and Colloid Chem.*, **51**, 816 (1947).

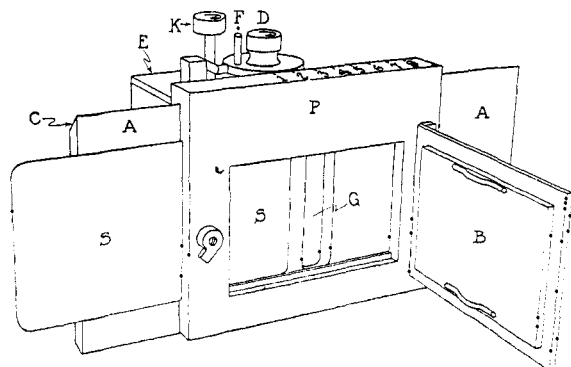

Fig. 1.—The plate holder.

accurate to 0.1% the fractional part, F , where $I + F = j_m$, must be known to within a few hundredths of a fringe. Consequently F was determined with the aid of the Rayleigh fringes into which the slit image degenerates when the lens is masked by a pair of horizontal slits. These fringes were photographed first with solution, say, in front of both slits and again with solvent in front of the upper one, *i. e.*, with the boundary between the slits. Although the position of the image envelope remained fixed the individual fringes in the second exposure were shifted downward with respect to those in the first by an amount proportional to F . As will be described below this shift was not measured directly but from the fringe positions in each exposure relative to reference fringes formed by light traversing the thermostat adjacent to the diffusion channel. Reference Rayleigh fringes were also used to locate precisely the undeviated slit image in the Gouy fringe pattern. In contrast with the work on sucrose the reference fringes for use in the location of this image were obtained with the aid of a twin double-slit whereas an ordinary double slit was used in the evaluation of F . Consequently, it was necessary to determine the vertical displacement, δ , of the slit image through the reference path with respect to that through the diffusion channel when using the twin double-slit and also that, δ' , when using the conventional double-slit. The photographic procedure was, therefore, somewhat involved and an understanding of it will probably require careful examination, by the reader, of Figs. 2, 3 and 4, together with the following text.

With solution in the diffusion channel, and isolated from that in the remainder of the cell by displacement of the center section to the left, the three consecutive exposures, a, b and c of Fig. 2, were made without shifting the photographic plate but with masking adjustments at both the plate and the cell between each exposure. In this figure the dashed lines at the cell represent openings in a fixed mask that expose the diffusion channel, on the left when in the isolated position, and on the right when aligned with the top and bottom sections. With the cell, which is indicated by the cross-hatching, in either position the other opening in this mask exposes both fluid adjacent to the channel. Superimposed upon the fixed mask at the cell is a horizontally sliding mask, indicated by the dotted lines, and also one of four numbered masking vanes, indicated by the full lines, that may be rotated into the position shown. It will be noted that openings in all three masks at the cell must overlap in order for light to be transmitted.

At the photographic plate, Fig. 2a for example, the dashed line represents the gate, G of Fig. 1, whereas the full lines represent one of a second set of four vanes that can be rotated, by means of the knob D of Fig. 1, into the position shown in avoiding superposition, on consecutive exposure, of the fringes from the diffusion and reference apertures.

The double slit in the sliding mask at the cell is 2 mm. between centers and symmetrically spaced about the optic axis, giving the Rayleigh pattern, Fig. 2b, for the slit image through the diffusion channel. The reference fringe segments in Fig. 2a, obtained with the cell masked as shown

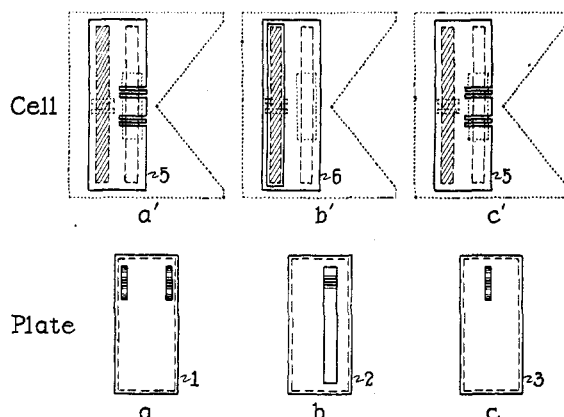

Fig. 2.—Exposure procedure for evaluation of the undeviated slit image position with a twin double-slit.

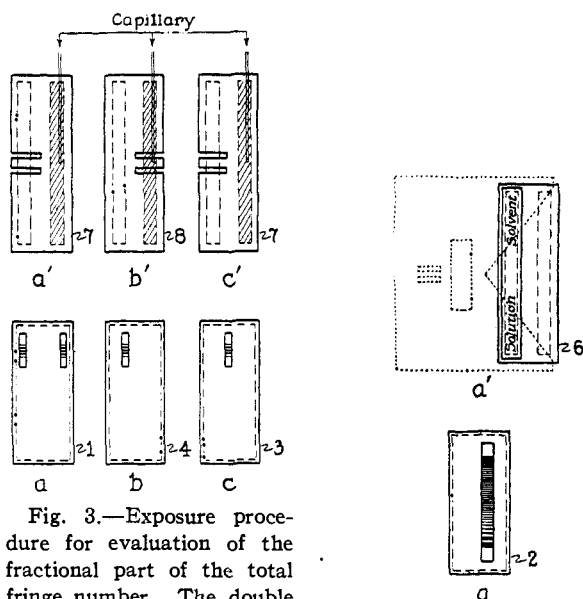

Fig. 3.—Exposure procedure for evaluation of the fractional part of the total fringe number. The double slit shown here is 10 mm. between centers and the width of each slit is 1.6 mm.

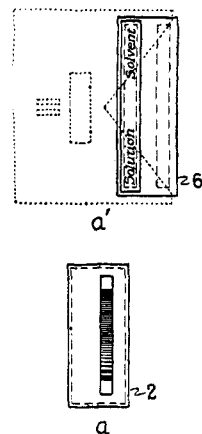

Fig. 4.—Exposure procedure for Gouy fringes.

in Fig. 2a', thus bracket the fringe segments, b, from the diffusion channel and provide a relatively long base for orientation of the plate in the comparator that is used in the measurement of the fringe spacing. The fringe segments at c from the reference opening are recorded to test for possible movement of the optical elements during the three exposures and are usually colinear with those in Fig. 2a within 3 microns. Several pictures of this type are taken in each experiment and the average displacement of the fringes in b from the mean of those in a and c is the value of δ , taken as positive if the shift is upward. By using closely spaced slits at the optic axis, Fig. 2b', δ is thus determined for that part of the channel where the center of the boundary will subsequently be located and through which the rays will pass that form the important lower Gouy fringes. Owing to the existence of a small angle between the windows of the channel, δ varied slightly with the refractive index of the solution and the value used at each mean concentration was taken from a smoothed plot of all δ values versus the concentration.

After removing the sliding mask and forming the boundary at the top of the diffusion channel, a capillary is in-

served to the level of the optic axis and several sets of the three consecutive exposures shown in Fig. 3 are made, thereby providing a value for δ' . Syphoning through the capillary is then begun and sets of three exposures made with the sharpened boundary centered between the slits when these mask the diffusion channel. If δ'' is now the average downward displacement of a diffusion channel fringe below one through the reference opening and Δ the fringe separation, $F = [(\delta'' + \delta')/\Delta] - N$. Here N is an integer, either positive, negative or zero, that is selected to make $0 \leq F < 1$ and is essential since the identity of a fringe cannot be carried from one Rayleigh pattern to another.

At zero time the syphoning is stopped, the capillary removed and the diffusion channel isolated. The Gouy fringes are then photographed at intervals with the same exposure sequence as in Fig. 2 except that the ends of the diffusion channel are now masked, as shown in Fig. 4a', with the horizontal V of the sliding mask that is progressively shifted to the left as the boundary spreads. The opening in vane 2 of the plate masking assembly is partially covered with a four-step filter⁸ to aid in counting the integral number, I , of fringes, i. e., $j_m = I + P$.

The Twin Double-Slit.—In order to avoid blurring of the Gouy fringes in the early photographs as the boundary spreads rapidly a short exposure is essential. At this stage, however, the boundary layer is still thin and comparatively little light goes into the fringe pattern. It is necessary, therefore, to increase the width of the source slit over that used in later photographs. Such a source is incompatible, however, with resolution of closely spaced Rayleigh fringes in the conventional reference exposure. In order to overcome this difficulty the twin double-slit shown in vane No. 5, Fig. 2a', was developed. The theoretical intensity pattern of the first order diffraction for this slit system is shown in Fig. 5 and the fringes actually observed correspond closely to this pattern. With a source slit of 0.07–0.2 mm. the fine fringes are blurred but the minima in their envelope are well defined and may be averaged to give, with the aid of δ , the position of the undeviated slit image. As the source slit is narrowed for the later Gouy photographs the fine fringes of Fig. 5 are resolved and can then be used to locate the slit image position with high precision.

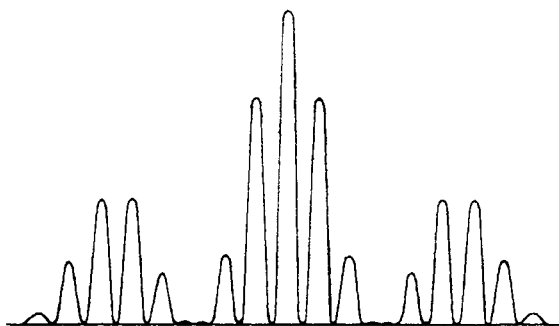

Fig. 5.—Theoretical intensity curve for a twin double-slit where the distance between the centers of the inner and outer pair is $10w$ and $14w$, respectively. In this work the width, w , of each slit is 0.8 mm.

Potassium Chloride Solutions.—Following one recrystallization with centrifugal drainage the reagent potassium chloride was fused in air and a weighed quantity dissolved in a known mass of air-saturated⁹ distilled water. With the aid of the following relations

$$d = 100/[w\varphi/M + (100 - w)/d_0] \quad (1)$$

$$\varphi = 26.742 + 2.000c/\% + 0.1110c \quad (2)$$

the weight per cent. of salt in vacuum, w , was converted to moles per liter, c , after one or two successive approxi-

mations for the density, d . Here $M = 74.553$, $d_0 = 0.997074$ and the limiting value of the apparent molal volume, φ , at 25° is taken from Owen and Brinkley.⁹ The coefficients of the concentration terms in the empirical equation 2 are those that fit the density data of Jones and Talley,¹⁰ Geffcken and Price¹¹ and Kruis¹² with an average deviation of one in the fifth decimal place up to their highest concentration of 3.7 N .

Results.—The results reported in Table I permit a direct comparison of the differential diffusion coefficient, D , of potassium chloride at 0.332 N , as obtained by the Gouy method, with the result of Harned and Nuttall³ at the same concentration. As can be seen in column 1 of the table, in this series of experiments the mean concentration, $\bar{c} = (c_s + c_0)/2$, between solution and "solvent" was held constant at 0.332 N but the increment, $\Delta c = c_s - c_0$, across the boundary was increased, column 2, from 0.1 to 0.4 N . Since there is no significant drift of the observed diffusion coefficients, column 3, with this increment the average value of 1.841×10^{-5} , weighted in proportion to the probable error, may be taken as the differential value at 0.332 N . This is in excellent agreement with the value, 1.842×10^{-5} , given by the conductance method. It should be emphasized that the experimental procedures for the two methods are quite different, with all data in the Gouy experiments being taken in the first stage of diffusion before the boundary spreads to the ends of the cell, while the conductance method utilizes data obtained in the second stage after appreciable solute has reached the top of the cell and a state of restricted diffusion has been attained.

In obtaining the diffusion coefficients of Table I, and also those of Table II, the Airy integral refinement⁶ of the "quarter-wave approximation"¹³ was used and measurements were restricted to the minima numbered 1 to 8 in each of the Gouy fringe photographs. From ten to twelve Gouy photographs were taken over a period of two hours in each experiment and the value of D was extrapolated to infinite time⁸ in

TABLE I
VALUES OF D AT A MEAN CONCENTRATION, \bar{c} , OF 0.332 N
FOR DIFFERENT CONCENTRATION INCREMENTS, Δc . $T = 25.00^\circ$

1	2	3	4	5
\bar{c}	Δc	j_m	$(\Delta n/\Delta c) \times 10^3$	$D \times 10^5$ sq. cm./sec.
0.33236	0.10073	45.40	9.802	1.8392
.33230	.15060	67.90	9.805	1.8415
.33230	.16999	76.62	9.802	1.8392
.33232	.18999	85.68	9.807	1.8418
.33196	.19965	90.02	9.805	1.8400
.33230	.22400	101.02	9.808	1.8425
.33230	.39997	180.52	9.815	1.8413

(9) Owen and Brinkley, *Ann. N. Y. Acad. Sci.*, **51**, 753 (1949).

(10) Jones and Talley, *This Journal*, **65**, 624 (1933); **65**, 4124 (1933).

(11) Geffcken and Price, *Z. physik. Chem.*, **B26**, 81 (1934).

(12) Kruis, *ibid.*, **B24**, 1 (1930).

(13) Kegeles and Gosting, *This Journal*, **69**, 2516 (1947).

(8) Longworth, *This Journal*, **69**, 2510 (1947).

TABLE II

DIFFUSION COEFFICIENT OF POTASSIUM CHLORIDE IN WATER AS A FUNCTION OF THE CONCENTRATION, \bar{c} . $T = 25.00^\circ$

1	2	3	4	5	6	7
\bar{c}	Δc	j_m	$(\Delta n / \Delta c) \times 10^3$	$D \times 10^5$ observed sq. cm./sec.	$\frac{D}{H} \times 10^5$	$\frac{D}{N} \times 10^5$ theory sq. cm./sec.
0.10000	0.20001	92.82	10.092	(1.8512)	1.845	1.8469
.22500	.20000	91.18	9.914	1.8382	1.837	1.8396
.33196	.19965	90.02	9.805	1.8400	1.841	1.8443
.50001	.20000	88.82	9.658	1.8497	1.851	1.8588
1.00005	.20006	85.59	9.304	1.8923		1.9206
1.50021	.20014	82.92	9.010	1.9427		2.0024
2.00034	.20017	80.69	8.766	1.9994		2.1040
2.50043	.20008	78.55	8.538	2.0569		2.2271
3.00080	.20014	76.69	8.333	2.1120		2.3727
3.50087	.20022	75.06	8.153	2.1603		2.5416
3.90080	.19963	73.52	8.009	2.1956		2.6941

order to correct for the slight, but unavoidable, initial mixing. In no experiment did the mean deviation of the points from this straight line extrapolation exceed 0.08% and the average zero time correction was 7.1 seconds, with a maximum of 8.7 seconds.

Also included in Table I are the total number of fringes, j_m (column 3), and the refractive increment per mole, $\Delta n / \Delta c$ (column 4), where $\Delta n = \lambda j_m / a$ and is referred to air as unity. Measurements with a bar and microscope⁴ gave 2.5110 cm. for the cell dimension, a , while 5460.7×10^{-8} cm. was taken as the wave length, λ , of the mercury green line.

In the series of experiments reported in Table II, D was measured as a function of the concentration of potassium chloride. Since the data of Table I indicate very little variation of D with Δc at a given mean concentration, \bar{c} , these measurements were made with $\Delta c \approx 0.2$ in order to utilize the greater precision that is possible when a moderately large concentration increment is used. The results should approximate closely to differential values except, possibly, at the lowest concentration where D changes rapidly with c . In Table II the column headings have the same significance as in Table I, two additional columns, 6 and 7, being included. Column 6 gives the values of D that may be interpolated from the conductometric results⁵ whereas those of column 7 have been computed, as will be described below, from the Onsager-Fuoss theory.

Values of D for the experiments below 1 N are plotted in Fig. 6 together with the results of Harned and Nuttall.^{2,3} From this figure and the data of Table II it may be seen that the conductance and optical methods agree to within 0.1% except for my point at 0.1000 N which seems high by at least one part in 500. This may be explained by the large variation of D over the concentration range from zero to 0.2 N .

Comparison with the Theory.—As a limiting law the Onsager-Fuoss theory¹⁴ cannot be ex-

(14) Onsager and Fuoss, *J. Phys. Chem.*, **36**, 2689 (1932).

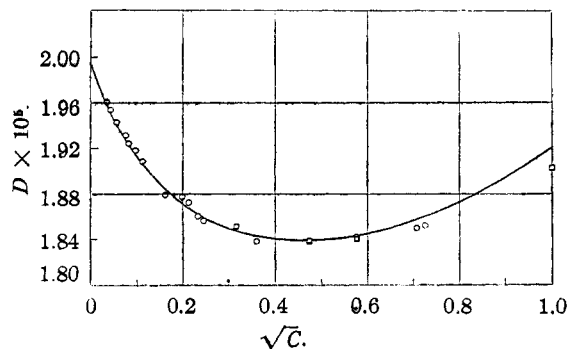

Fig. 6.—The diffusion coefficients of potassium chloride at 25°: □, this research; ○, Harned and Nuttall; —, Onsager-Fuoss theory.

pected to agree quantitatively with experiment at the concentrations of this research. It is of interest, nevertheless, to make the comparison in order to indicate the direction in which further progress in the elaboration of the theory can be expected. For a salt such as potassium chloride their relation is

$$D = 2000RT \left(\frac{M}{c} \right) \left(1 + c \frac{d \ln f}{dc} \right) \quad (3)$$

where f is the mean ion activity coefficient on a volume concentration scale, c , and the diffusion mobility is

$$\frac{M}{C} = \frac{10^{-10} \lambda_1 \lambda_2}{F^2 (\lambda_1 + \lambda_2)} - \left(\frac{\lambda_1 - \lambda_2}{\lambda_1 + \lambda_2} \right)^2 \frac{10^{-5} \epsilon}{6\eta (1 + A' \sqrt{c})} \sqrt{\frac{20c}{\pi RDT}} + \frac{10^{-5} N^2 \epsilon^4}{3\eta (RDT)^2} C \varphi (A' \sqrt{c}) \quad (4)$$

Here the customary symbols have been used for the universal constants to which the following values¹⁵ have been assigned: $F = 96496$, $N = 6.0235 \times 10^{23}$, $\epsilon = 4.8024 \times 10^{-10}$ and $R = 8.3144 \times 10^7$. At 25°, *i. e.*, $T = 298.16$, the equivalent ion conductances, λ_K and λ_{Cl} , are 73.52 and 76.34, respectively,¹⁶ whereas the viscosity, η , of water is 8.929×10^{-3} and its dielectric constant, D , is 78.54. Since the function $\varphi(A' \sqrt{c})$ may be computed from the table given by Harned and Owen¹⁷ and

$$A' = \frac{N\epsilon}{50} \sqrt{\frac{20\pi}{RDT}} a^0 \quad (5)$$

there remains only the assignment of a value to the ion size parameter, a^0 , in order to compute the mobility as a function of c .

This parameter also enters into the expression for the activity coefficient and in fitting the various empirical extensions of the Debye-Hückel theory to the experimental data the value obtained de-

(15) DuMond and Cohen, *Rev. Modern Phys.*, **20**, 82 (1948).

(16) MacInnes, "The Principles of Electrochemistry," Reinhold Publishing Corp., New York, N. Y., 1939, p. 342.

(17) Harned and Owen, "The Physical Chemistry of Electrolytic Solutions," Reinhold Publishing Corp., New York, N. Y., 1950, p. 130.

pends somewhat upon the function that is used. Preliminary computations showed that equation 3 would fit the diffusion data up to a concentration of about 0.3 *N* if a^0 was 3.5 Å. Consequently, this value was also used in obtaining the following expression for

$$\log f = \frac{-0.50891\sqrt{c}}{1 + 1.150\sqrt{c}} - 0.0240c \log c + 0.0272c + 0.00577c^2 - \log [(d/d_0) - 0.038634c] \quad (6)$$

that reproduces the activity data of Shedlovsky¹⁸ for $0 < c < 0.2 N$ with a maximum deviation of 0.0005 and that of Robinson and Stokes¹⁹ for $0.1 < c < 4 N$ with a maximum deviation of 0.002. The values of *D* in column 7 of Table II and the curve of Fig. 6 were then obtained with the aid of equations 1 to 6 and $a^0 = 3.5$.

The theory predicts not only the form of the concentration dependence of the diffusion coefficient but also the approximate position of the minimum in the curve. Above 0.3 *N* the computed values increase more rapidly with the concentration than the observed ones, suggesting, as others have noted,^{3,14} the possible influence of the increasing viscosity of the solution. Aqueous potassium chloride at 25° is not, however, a good system with which to study the possible effects of viscosity since this property does not differ, except at high concentrations, by more than a few tenths of a per cent. from that of water.

It will be noted that the a^0 value used here is lower than the 3.8 employed by Harned and Nuttall² and the 4.6 found by Shedlovsky.¹⁸ If a value of 4.6, say, is used the theoretical curve then sags below the experimental points in the neighborhood of the minimum before rising too rapidly with *c* at the higher concentrations. An independent and reliable method for the evaluation of this ion size parameter would, therefore, be desirable.

Measurements at Other Wave Lengths.—In addition to obtaining the data of Tables I and II with the green line, the blue triplet and the yellow doublet of the AH4 mercury lamp were studied as sources in the experiments with $\bar{c} = 0.22500$ and $\bar{c} = 1.00005$. A combination of Wratten 2A and 35 filters was used to isolate the blue triplet, while a Wratten 22 filter served to isolate the yellow doublet. Since no informa-

tion was found describing the intensity distribution of the doublet, and the intensity ratios given by Rank and McCartney²⁰ for the triplet probably do not apply to the AH4 lamp, weighted mean values for the wave lengths could not be assigned. Therefore, the usual procedure was reversed and diffusion coefficients obtained from measurements with the 5460.7 line for the two experiments were used to calculate the effective mean wave lengths for the doublet and the triplet. Values of 5776×10^{-8} cm. and 4357×10^{-8} cm., respectively, were obtained. In the case of the blue triplet the computed value agrees well with the wave length, 4358.3×10^{-8} cm., of the principal line. In the case of the yellow doublet the computed value corresponds to 70% of the total doublet intensity being in the line of shorter wave length. In either case, the agreement is such as to provide a fair confirmation of the wave length term in the Gouy theory.

As might be expected, the Rayleigh fringes were somewhat blurred with the doublet and triplet sources, but measurable fringes were obtained by carefully controlling the exposures. When using large concentration increments, Δc , the Rayleigh pictures with the 5460.7 line are also slightly blurred. This is probably due either to pressure broadening of the line or to the background light inherent in the AH4 lamp.

Acknowledgment.—The author wishes to thank Dr. Lewis G. Longworth for suggestions and helpful discussion throughout the course of this work and during the preparation of the manuscript. The continued interest and encouragement of Dr. D. A. MacInnes are gratefully acknowledged. This research was made possible by a fellowship from the National Research Council.

Summary

With the aid of the Gouy interference method the concentration dependence of the diffusion coefficient of potassium chloride in water has been measured from 0.1 to 3.9 *N*. In the concentration range from 0.1 to 0.5 *N*, where these data overlap those obtained by Harned and Nuttall with a conductance method, the results of the two procedures are in agreement within 0.1%.

NEW YORK, N. Y.

RECEIVED MARCH 1, 1950

(18) Shedlovsky, *This Journal*, **72**, 3680 (1950).

(19) Robinson and Stokes, *Trans. Faraday Soc.*, **45**, 612 (1949).

(20) Rank and McCartney, *J. Opt. Soc. America*, **38**, 279 (1948).